

) NPX 3x00-IPDB

IP Decoder Board for Netpix Controllers

The new IP streaming video decoding solution from eyevis offers the next generation of universal decoding of IP streams from cameras, encoders and DVRs over video IP networks. This new full-digital solution for decoding for IP camera surveillance systems provides a lot of benefits, such as the display of numerous camera signals on a display wall.



) KEY BENEFITS

- Universal decoding solution for multiple codec formats and for systems of different camera / encoder manufacturers.
- Reduces costs for equipments, setup, and maintenance
- Fully digital solution with high image quality and a low latency
- Very flexible (upgradable for future requirements) and expandable
- Real-time decoding
- Decodes resolutions from CIF, D1 up to MegaPixel

) CONFIGURATION

Through the open architecture of the NPX3x00 family, the IPDB board can be used in all NPX3000/3800 and NPX3800XE systems. It is possible to mix multiple inputs boards, e.g. analogue video input boards or RGB/DVI boards together with the IPDB board. The result is a very powerful controller with many different types of inputs, without using a second system. The IPDB board can also be used with more expansion chassis to decode hundreds of streams in one controller. Because of this advantage future upgrades become very easy without the necessity to exchange the entire hardware.

) INTEGRATION

The setup and configuration of each board and channel can be easily done with the eyecon software. All settings are performed by drag&drop without editing ini files etc. Changes during transmissions are also possible inside the setup configuration side.

- Support of thousands of cameras
- Dynamic virtual switching of each camera to a decoder channel
- Fast switching between cameras, also independent from codec changes
- Dynamic use of available decoders or static mode
- Overview of all camera/encoder sources in a customizable list
- Support for additional comments for each camera
- Free labelling of each source and OSD support
- API for easy integration and support of many different video management software solutions

) IP NETWORK CONNECTION

The IP video streaming board features two 10/100/1000Mbit Base-T Ethernet interfaces. They can be used for independent networks or redundancy purposes.

) SUPPORTED NETWORK PROTOCOLS

- IP
- UDP
- RTP (Real-Time Protocol over Ethernet)
- RTSP (Real-Time Streaming Protocol)
- Multicast and Unicast for these protocols are also supported.



) NPX-3x00-IPDB



IP Decoder Board for Netpix Controllers

) DECODING OVERVIEW

The Decoder board is equipped with a powerful processor which can handle up to 8 streams with a resolution in D1 Quality and 25frames/s. Through the new hardware architecture also 32 streams in CIF quality are possible per decoder card. Megapixel Resolutions are supported as well.

One IPDB board can decode in real-time with 25/30 frames:

32 x CIF 352x288 / 8 x D1 720x567 / 2 x Megapixel 1280x1024

Different codec formats* can be decoded simultaneously on one decoder board, with no dependence on the resolution.

MPEG2 ISO/IEC-13818 / MPEG4 Part2 ISO/IEC-14496-2 / MPEG4 (H264) ISO/IEC-14496-10 (AVC) / MJPEG Motion JPEG

*) List of Codec formats is continuously updated

) TECHNICAL SPECIFICATIONS

Network specifications

Network Ports	2x Ethernet RJ-45 1000 Base-T Ports Auto-sensing, Half/Full Duplex
Redundancy	Ports can be defined as redundancy ports
Network Protocols	TCP, UDP, IP, RTP, RTSP. Multicast and Unicast
IP Addresses	Possibility to define 2x independent IP-Addresses

Universal Decoding specifications

Maximum Decoder channels	32 channels simultaneously per board
Frame rates per Channel	PAL (25 fps) or NTSC (30 fps)
Resolution range per channel	352x288 (CIF), 720x567 (D1), 1280x1024 (MP)
Maximum channels per board	32x CIF or 8x D1 or 2x MP
Codec Formats	Independent codecs for each channel
Supported Codec formats	MPEG2 ISO/IEC-13818 Profiles: ES, PS and TS MPEG4 Part2 ISO/IEC-14496-2 Profiles: ASP, SP MPEG4 (H264) ISO/IEC-14496-10 (AVC) MJPEG Motion JPEG
Decoding Delay	Decoding delay 200 ms with MPEG2 / 150ms with MPEG4

Hardware & Scalability

Boards per System	Up to 16 boards can be integrated over the special HSIB BUS in the NPX-Controller
Expansions	Up to two additional expansions to support 8x IPDB per chassis

) SYSTEM OVERVIEW

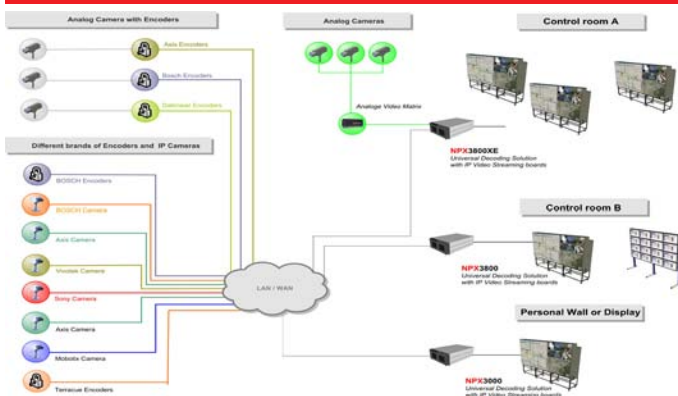

) SUPPORTED CAMERA-/ENCODER MANUFACTURERS

- ATEME MPEG4 / H264
- acTi MPEG4 / H264
- AXIS MPEG4 / MJPEG
- BOSCH MPEG-4
- Canon
- Dallmeier MPEG2 / MPEG4
- DLINK
- IndigoVision MPEG-4 / H264
- Mavix MPEG2 / MPEG4
- Mobotix MxPEG
- Teracue MPEG2
- Truen H264
- Vivotek MPEG4
- Vibrick VB6000
- Windows Media Encoder
- Siemens Building SISTORE Cx MPEG4
- Optelecom/NKF MPEG-2/4
- Lanacess MPEG2/4
- Comerson MPEG2/4
- Sony

Planned Q4/2009:

- Panasonic
- Synectics



eyevis UK Ltd

PO Box 482 • Burnley
Lancashire • BB11 9BX • United Kingdom
Tel: +44(0)1282 606525 • Fax: +44(0)1282 697703
www.eyevis.co.uk • enquiry@eyevis.co.uk
As at: August 2009 • Subject to change!
Copyright © 2009 eyevis GmbH. All Rights Reserved.